

### Description

The HWA1440 is a high-efficiency, wide instantaneous bandwidth, fully input/output matched power amplifier (PA) with high gain and linearity.

The compact 16-pin 5 × 5 mm PA is designed for FDD and TDD systems, supports 5G NR FR1 bands n79 wireless infrastructure operating from 4400 to 5000MHz.

The active biasing circuitry is integrated to compensate PA performance over temperature, voltage, and process variation.

This amplifier is part of Hexawave's high-efficiency 4W PA RF product line designed for wireless infrastructure supporting major 3GPP bands.

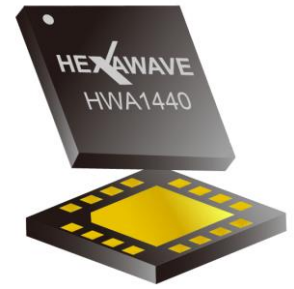

### Features

- Wide instantaneous signal bandwidth
- High Efficiency
- High Linearity (5G, 8.5 dB PAR signal)
- Single supply voltage :  $V_{cc} = 5.0\text{ V}$
- Integrated active bias : performance compensated over temp
- 50  $\Omega$  matched input and output
- Compact (16-pin, 5 × 5 × 1.3 mm) package
- MSL3, 260 °C per JEDEC J-STD-020

### Applications

- Supports 5G FDD and TDD systems
- Supports 3GPP 5G NR FR1 bands n79
- Small cells for wireless communications infrastructure and massive MIMO
- Repeaters / DAS
- General purpose wireless

### Functional Block Diagram

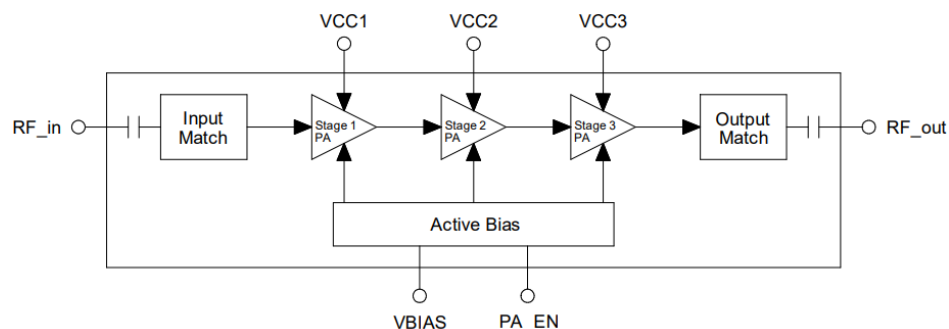



## ■ User Applications

The products are not intended to any application which is not specified in this document. For other application, please be noted that a different product may be required. If you have any concerns, please contact us before using the products in your desired application. This specification guarantees the quality and performance of the products as an individual component. Do not use the products beyond the use case and use environment that the specification has described in this document. We assume no responsibility and liability for any lost and damage resulting from the use or operation of the products which do not comply with any absolute maximum ratings, warnings, restrictions and instructions recited in these specification sheets or other forms of notices from us or resulting from the use or operation of the products under non-standard environment or operations.

## ■ Cautions

All measurement data is taken from standard laboratory procedures on each discrete product. The procedure does not work on any product integrating components and materials not provided by us. The measurement is provided for your reference and evaluation on your integrated products only. Therefore the products should always be cautiously used with other parts on your own. It is your or your customer's responsibility to perform sufficient tests under your expected environment prior to use the products with other parts to ensure that the lifetime and other quality characteristics required for the actual use in real life are met. During your tests, it is recommended to actively consult with us instantly while there is any concern or inconsistency about the discrete component. Caution: While using under non-standard environment, application or non-approval operations, be aware of malfunctions or damages leads to risks of life or health.

You will not reverse engineer, disassemble or otherwise attempt to extract knowledge/design information from the products. In the case of any incident or quality concern that appears to be in breach of these specifications, the products in question must be reported to our local sales representatives for further instructions. Please ensure that the products in question are not disassembled or removed from the PCBs(if any). The determination of whether the products in question are defective and are required for any corrective action thereafter shall be made by us in accordance with our cause analysis procedure. If you do not agree with our cause analysis result, you may request us to send the products in question to a mutually agreed third party for inspection. The cost of such third party inspection shall be borne by you unless it is determined by such third party that said quality issue is solely attributable to us. In the above case, our sole and exclusive obligation shall be, either to repair, replace or refund the products in question.

## ■ Disclaimers

REPAIR, REPLACE OR REFUND OF THE Products SHALL CONSTITUTE THE SOLE AND EXCLUSIVE REMEDY FOR THE PRODUCTS. WE EXPRESSLY EXCLUDE ALL EXPRESS WARRANTIES IN RELATION TO THE PRODUCTS INCLUDING THE IMPLIED WARRANTIES OF MERCHANTABILITY AND FITNESS FOR A PARTICULAR PURPOSE.

BOTH PARTIES AGREE THAT BEFORE YOUR CONSENT TO THE DOCUMENT, WE RESERVE RIGHTS TO MODIFY AND DISCARD THE FORMER VERSION OF THE DOCUMENT AND THE CONSENT IN THIS CLAUSE INCLUDING A WRITTEN COSENT OR BEGINNING AN ACTUAL PERFORMANCE ON DEALINGS.